



With transport option



Without transport option

Supplier: This manual must be given to the user/care giver of this wheelchair.

Rider: Before using this wheelchair, read this entire manual and save for future reference.

NXT™

Generation NEXT



Pediatric & Adult
Folding Tilt Wheelchair



Our kids are our passion™

Operator's Manual



NXTOM1/25/11

Congratulations on your purchase of the Freedom Designs, Inc. NXT wheelchair. These chairs combine state-of-the-art technology with durability and functionality to meet all of your changing needs. This Operating Manual provides you with a detailed guide for proper assembly as well as instructions on the care of your new wheelchair. Please follow the instructions carefully, paying special attention to the Safety Precaution section. It is important to read the entire Operating Manual before operating the wheelchair. After consulting your Operating Manual, if you feel you have further questions, please contact one of our Authorized Providers or our Customer Service Department at:

(800) 331-8551

Again, thank you for your purchasing a Freedom Designs, Inc. NXT
This manual created on January 25th, 2011

Serial # _____

Reference Phone Numbers:

Home Medical Equipment Supplier Name _____

Phone # _____

Home Health Care Agency Name _____

Phone # _____

Doctor Name _____

Phone # _____

Supplier _____

Address: _____

Telephone: _____

Serial # _____ Purchase Date _____

Table of Contents

Introduction	1	Power Drive	13
Table of Contents	2	Push Handles	13
General Warnings	3-5	Quick Release Axles	13
Weight Limit	3	Rear Wheels	13
Every Wheelchair is Different	3	Wheel Locks	13
Reduction of Risk of an Accident	3	Modified Seating Systems	13
Safety Checklist	3	Upholstery Fabric	14
Adjustments	3	Initial Inspection Checklist	15
Environmental Conditions	4	Features	16
Terrain	4	Unfolding the NXT	17-18
Street Use	4	Folding the NXT	19-20
Motor Vehicle Safety	4	Main Frame	21-26
Assistance	5	Latch Style Swing Away	
Warnings:		Hangers	21
Falls & Tip-Overs	5-9	Pop-up Hangers	22
Center of Balance	5	Flip-up Individual Footplates	23
Dressing or Changing Clothes	6	Angle Adjustable Footboard	24
Wheelies	6	Quick Release Axles	25
Obstacles	6	Flip Back and "T"- Armrests	25
Reaching or Leaning	6	Fixed Height, Removable	26
Moving Backward	7	Armrests	
Ramps, Slopes & Side Hills	7	Adjustable Height Flip Back	26
Transfer	8	Armrests	
Curbs and Steps	8	Casters	26
Stairs and Escalators	9	Wheel Locks	26
Warnings:		Folding Back	27
For Safe Use	9-11	Tilt Operation	27-28
Transport Use	9	Leverage Bar Operation	28
Descending a Curb or		NXT Adjustments	29-32
Single Step	9	Tilt Cable Adjustment	29
Climbing a Curb or Single Step	10	Backpost Adjustments	29
Climbing Stairs	10	Armrest Adjustments	29-30
Descending Stairs	10	Caster Fork Adjustments	30
Tilting Seat	10	Wheel Lock Adjustments	30
Maintenance	11	Rear Axle Adjustments	31
Warnings:		Anti-tip Adjustment	31
Components and Options	11-14	Pelvic Belt Installation & Use	32
Transport Option	11	Cleaning	33
Anti-Tip Device	11	Maintenance	33
Armrests	11	Storage	33
Cushions and Sling Seats	11	Troubleshooting	34
Fasteners	12	Summary	35
Pneumatic Tires	12	Warranty	36
Footrests	12		
Positioning Belts	12		

Warnings and Caution statements included in this manual describe conditions and unsafe practices which might result in bodily injury or property damage. Read this entire manual before assembly or operation of this wheelchair. If you do not understand any of the instructions in this manual, call your authorized Freedom Designs, Inc. provider. Note: Where they apply, you will also find “Warnings” in other sections of this manual. Heed all warnings in this section.



W A R N I N G

The weight limit for the NXT tilt is a **200 lb.** person. If the person exceeds the weight limit (including items carried), damage to your chair, a fall, tip-over or loss of control may cause severe injury to the rider or others.

Every wheelchair is different. Become familiar with your chair before you begin riding. Start slowly, with easy, smooth strokes. Be careful not to use too much force, which might result in tipping over, damage to your chair, a fall, or loss of control, which may occur and cause severe injury to the rider or others.

Reduction of Risk of an Accident:

1. **BEFORE** riding, you should be trained in the safe use of this chair by your health care advisor.
2. Practice bending, reaching and transfers until you know the limit of your ability. In order to avoid tipping over, have someone help you, until you know what can cause a fall.
3. Be aware that you must develop your own methods for safe use best suited to your level of function and ability.
4. **NEVER** try a new maneuver on your own until you are sure you can do it safely.
5. Get to know the areas where you plan to use your chair. Look for hazards and learn how to avoid them.

Safety Checklist

1. Before each use of your chair:
2. Make sure the chair rolls easily and that all parts work smoothly. Check for noise, vibration, or a change in ease of use. (They may indicate low tire pressure, loose fasteners, or damage to your chair).
3. Repair any problems. Consult your Freedom Designs, Inc. authorized provider for help in finding or correcting the problem.
4. Check to see that both quick-release axles are locked. When locked, the axle button will “pop out” fully. If not locked, the wheel may come off and cause you to fall.

Adjustments

1. If you modify or adjust this chair, it may increase the risk of a tip-over UNLESS you make other changes as well.
2. Before any adjustments or modifications are made to your chair, consult your authorized Freedom Designs, Inc. provider.
3. Unauthorized modifications or use of parts not supplied or approved by Freedom Designs, Inc. may damage the chair structure. This will void the warranty and may cause a safety hazard.



If you fail to heed these warnings, damage to your chair, a fall, tip-over, or loss of control may occur and cause severe injury to the rider or others.



Environmental Conditions

Use extra care if you must ride your chair on a wet or slick surface. Ask for help, if you are in doubt.

Contact with water or excess moisture may cause your chair to rust or corrode. This could cause your chair to fail.

- a. Do not use your chair in a shower, pool or other body of water. The chair tubing and parts are not watertight and may rust or corrode from the inside.
- b. Avoid excess moisture, (for example, do not leave your chair in a damp bathroom while taking a shower).
- c. Dry your chair as soon as you can if it gets wet or if you use water to clean it.



W

Terrain

1. Your chair is designed for use on firm, even surfaces such as concrete, asphalt, and indoor floors and carpeting.
2. Do not operate your chair in sand, loose soil, or over rough terrain. This may damage wheels or axles or loosen fasteners of your chair.

A

Street Use

1. In most states, wheelchairs are not legal for use on public roads. Be alert to the danger of motor vehicles on roads or in parking lots.
2. At night, or when lighting is poor, use reflective tape on your chair and clothing.
3. Due to your low position, it may be hard for drivers to see you. Make eye contact with drivers before you go forward. When in doubt, yield until you are sure it is safe.

R

N

I

Motor Vehicle Safety

As identified on the front cover of this user manual, identify whether your chair has been manufactured with the Transport Option installed.

N

If your chair is not equipped with the Transport Option:

G

The NXT wheelchairs do not meet federal standards for motor vehicle seating.

1. **NEVER** let anyone sit in this chair while in a moving vehicle.
 - a. **ALWAYS** move the rider to an approved vehicle seat.
 - b. **ALWAYS** secure the rider with proper motor vehicle restraints.
2. In an accident or sudden stop, the rider may be thrown from the chair. Wheelchair hip belts will not prevent this and further injury may result from the belts or straps.
3. **NEVER** transport this chair in the front seat of a vehicle. It may shift and interfere with the driver.
3. **ALWAYS** secure this chair so that it can not roll or shift.
4. Do not use any chair that has been involved in a motor vehicle accident.



If your chair is equipped with the Transport Option, see the Transport Option Warnings.

If you fail to heed these warnings, damage to your chair, a fall, tip-over, or loss of control may occur and cause severe injury to the rider or others.



Assistance For the Rider:

Everyone who helps you needs to read and follow all warnings and instructions that apply.

For Attendants

Work with the rider's doctor, nurse or therapist to learn safe methods best suited to your abilities and those of the rider.

Tell the rider what you plan to do and explain what you expect the rider to do. This will put the rider at ease and reduce the risk of an accident

Make sure the chair has push handles. They provide secure points for you to hold the rear of the chair to prevent a fall or tip-over. Check to make sure push handle grips will not rotate or slip off.

To prevent injury to your back, use good posture and proper body mechanics. When you lift or support the rider, bend your knees slightly and keep your back as straight as you can.

Remind the rider to lean back when you tilt the chair backward.

When you descend a curb or single step, slowly lower the chair in one easy movement. Do not let the chair drop the last few inches to the ground. This may damage the chair or injure the rider.



W

A

R

N

I

N

G



WARNING: FALLS & TIP-OVERS

Center of Balance

The point where this chair will tip forward, back, or to the side depends on its center of balance and stability. How your chair is setup, the options you select, and the changes you make affect the risk of fall or tip-over.

1. The most important adjustments are:
 - a. The position of the rear wheels. The more you move the rear wheels forward, the more likely your chair will tip over backward.
2. The center of balance is also affected by:
 - a. A change in setup of your chair, including:
 1. The distance between the rear wheels.
 2. The seat height, seat angle and position on frame.
 3. The backrest angle.
 - b. A change in your body position, posture or weight distribution.
 - c. The use of a back pack or other options, and the amount of added weight.
3. To reduce the risk of an accident:
 - a. Consult your doctor, nurse, or therapist to find out what axle and caster position is best for you.
 - b. Consult your authorized Freedom Designs, Inc. provider BEFORE you modify or adjust this chair. Be aware that you may need to make other changes to correct the center of balance.
 - c. Have someone help you until you know the balance points of your chair and how to avoid a tip-over.
 - d. Use anti-tip tubes.

If you fail to heed these warnings, damage to your chair, a fall, tip-over, or loss of control may occur and cause severe injury to the rider or others.



Dressing or Changing Clothes

Your weight may shift if you dress or change clothes while seated in this chair. To reduce the risk of a fall or tip-over:

Rotate the front casters until they are as far forward as possible. This makes the chair more stable.

Lock wheel locks into place.



Wheelies

“Wheelies”, (tilting the wheelchair backward to its balance point), are extremely dangerous as the chair may tip over. Freedom Designs, Inc. recommends that “wheelies” not be attempted.

Obstacles

Obstacles and road hazards (such as potholes and broken pavement), can damage your chair and may cause a fall, tip-over, or loss of control.

To avoid these risks:

Keep a lookout for danger—scan the area well ahead of your chair as you ride. Make sure the floor area where you live and work are level and free of obstacles.

Remove or cover threshold strips between rooms.

Install a ramp at entry or exit doors. Make sure there is not a drop off at the bottom of the ramp.

To help correct your center of balance:

- a. Lean your upper body FORWARD slightly as you go UP over an obstacle.
- b. Press your upper body BACKWARD as you go DOWN from a higher to a lower level.

Keep both of your hands on the handrims as you go over an obstacle.

Never push or pull on an object, (such as furniture or a doorjamb), to propel your chair.

Reaching or Leaning

If you reach or lean, it will affect the center of balance of your chair. This may cause you to fall or tip over. When in doubt, ask for help or use a device to extend your reach.

1. **NEVER** reach or lean if you must shift your weight sideways or rise up off the seat.
2. **NEVER** reach or lean if you must move forward in your seat to do so. Always keep your buttocks in contact with the backrest.
3. **NEVER** reach with both hands, you may not be able to catch yourself to prevent a fall if the chair tips.
4. **DO NOT** reach or lean over the top of the seat back. This may damage one or both backrest tubes and cause you to fall.
5. If you must reach or lean:
 - a. Do not lock the Drive wheels. This creates a tip point and makes a fall or tip-over more likely.
 - b. Do not put pressure on the footrests.

Note: Leaning forward puts pressure on the footrests and may cause the chair to tip if you lean too far.

If you fail to heed these warnings, damage to your chair, a fall, tip-over, or loss of control may occur and cause severe injury to the rider or others.

W

A

R

N

I

N

G





- c. Move your chair as close as you can to the object you wish to reach.
- d. Do not try to pick up an object from the floor by reaching down between your knees. You are less likely to tip if you reach to the side of your chair.
- e. Rotate the front casters until they are as far forward as possible.
This makes the chair more stable.
Note: To do this: Move your chair past the object you want to reach, then back up alongside it. Backing up will rotate the casters forward.
- f. Firmly grasp an armrest with one hand. This will help to prevent a fall if the chair tips.

Moving Backward

Use extra care when you move backward. Your chair is not stable when you propel yourself rearward. You may lose control or tip over if one of the large Drive wheels hits an object and stops rolling.

Propel your chair slowly and smoothly.

Stop often and check to be sure your path is clear.

If you fail to heed these warnings, damage to your chair, a fall, tip-over, or loss of control may occur and cause severe injury to the rider or others.

Ramps, Slopes & Side Hills

Riding on a slope, which includes a ramp or side hill, will change the center of balance of your chair. Your chair is less stable when it is at an angle. The rear stabilizing wheel may not keep the chair from going over backward.

1. Do not use your chair on a slope steeper than 10%. (A 10% slope means: one foot in elevation for every ten feet of slope length).
2. Always go as straight up and as straight down as you can. (do not “cut the corner” on a slope or ramp).
3. Do not turn or change direction on a slope.
4. Always stay in the **CENTER** of the ramp. Make sure ramp is wide enough that you are not at risk that a wheel may fall over the edge.
5. Do not stop on a steep slope. If you stop, you may lose control of your chair. **NEVER** use wheel locks to try to slow or stop your chair. This is likely to cause your chair to veer out of control.
7. Beware of:
 - a. Wet or slippery surfaces.
 - b. A change in grade on a slope (or a lip, bump or depression). These may cause a fall or tip-over.
 - c. A drop-off at the bottom of a slope. A drop-off of as small as 3/4” can stop a front caster and cause the chair to tip forward.
8. To reduce the risk of a fall or tip-over:
 - a. Lean or press your body UPHILL. This will help adjust for a change in the center of balance caused by the slope or side hill.
 - b. Keep pressure on the handgrips to control your speed on a down slope. If you go too fast, you may lose control.
 - c. Ask for help any time you are in doubt.
9. For your safety, ramps at home and work must meet all legal requirements for your area.

If you fail to heed these warnings, damage to your chair, a fall, tip-over, or loss of control may occur and cause severe injury to the rider or others.



W

A

R

N

I

N

G



We recommend:

- a. Width: At least four feet wide.
- b. Guardrails. To reduce the risk of a fall, sides of ramp must have guardrails (or raised borders at least three inches high).
- c. Slope. Not more than a 10% grade.
- d. Surface. Flat and even, with a thin carpet or other nonskid material. (Make sure there is no lip, bump or depression).
- e. Bracing. Ramp must be STURDY. You may need a section at the top or bottom to smooth out the transition.

Transfer

It is dangerous to transfer on your own. It requires good balance and agility. Be aware that there is a point during transfer when the wheelchair seat is not below you. To avoid a fall:

1. Work with your health care advisor to learn safe methods.
 - a. Learn how to position your body and how to support yourself during a transfer.
 - b. Have someone help you until you know how to do a safe transfer on your own.
2. Lock large Drive wheels before you transfer. This keeps the large wheels from rolling.

Note: This will NOT keep your chair from sliding away from you or tipping.
3. Make sure to keep pneumatic tires properly inflated. Low tire pressure may allow the wheel locks to slip.
4. Move your chair as close as you can to the seat you are transferring to. If possible, use a transfer board.
5. Rotate the front casters until they are as far forward as possible.
6. Remove footboard, if possible.
 - a. Make sure your feet do not catch in the space between the footrests.
 - b. Avoid putting excessive weight on the footboard, as this may cause the chair to tip.
7. Make sure armrests are out of the way and do not interfere.
8. Transfer as far back onto the seat surfaces as you can. This will reduce the risk that the chair will tip or move away from you.

Curbs & Steps

1. Each person who helps you should read and follow the warnings—"For Safe Use" (Pages 9-10).
2. Do not try to climb or descend a curb or step alone UNLESS you are a skilled rider of this chair and you are sure you have the strength and balance to do so.
3. Do not try to climb a high curb or step, more than 4" high, UNLESS you have help. Doing so may cause your chair to exceed its balance point and tip over.
4. Go straight up and down a curb or step. If you climb or descend at an angle, a fall or tip-over is likely.
5. Be aware that the impact of dropping down from a curb or step can damage your chair or loosen fasteners.

If you fail to heed these warnings, damage to your chair, a fall, tip-over, or loss of control may occur and cause severe injury to the rider or others.

Stairs and Escalators

1. **NEVER** use this chair on stairs **UNLESS** you have someone to help you. Doing so is likely to cause a fall or tip-over.
2. Persons who help you should read and follow the warnings “For Attendants”, (page 6) and the “For Safe Use”, (pages 9-10).
3. **NEVER** use this chair on an escalator, even with an attendant. If you do, a fall or tip-over is likely.

WARNING: FOR SAFE USE

Before you assist a rider, be sure to read the warnings “For Attendants” (page 5) and follow all instructions that apply. Be aware that you will need to learn safe methods best suited to your abilities.

Transport Use

If possible and feasible, the rider should transfer to the OEM vehicle seat and use the vehicle restraint. If the wheelchair is used for transport, it must be used in a forward-facing seating position.

The ANSI/RESNA WC/19 standards apply to persons with a weight of 51 to 169 lbs. This constitutes the range of sizes for which the wheelchairs are suitable for occupancy in a motor vehicle.

The picture (right) shows the location of the wheelchair securement points. Use only with Wheelchair Tiedown and Occupant Restraint Systems (WTORS) that have been installed in accordance with the manufacturer’s instructions and SAE J2249.

Attach WTORS to securement points in accordance with the manufacturer’s instructions and SAE J2249

Attach occupant restraints in accordance with the manufacturer’s instructions and SAE J2249.

Note: To obtain a copy of SAE J2249 Wheelchair Tiedown and Occupant Restraints Systems for Use in Motor Vehicles, please contact:

SAE International—400 Commonwealth Drive—Warrendale, PA 15096
(412) 776-4970

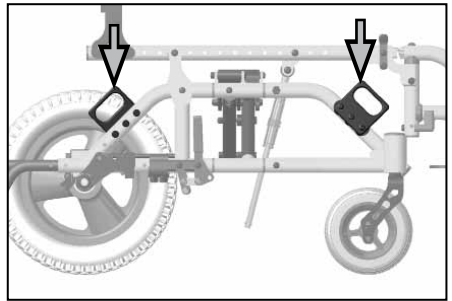
**Descending a Curb or Single Step with Attendant**

Follow these steps to help a rider descend a curb or single step going down **BACKWARD**:









1. Stay at the rear of the chair.
2. Several feet before you reach the edge of the curb or step, turn the chair around and pull it backward.

If you fail to heed these warnings, damage to your chair, a fall, tip-over, or loss of control may occur and cause severe injury to the rider or others.

- 
3. While looking over your shoulder, carefully step back until you are off the curb or stair and standing on the lower level.
 4. Pull the chair toward you until the large Drive wheels reach the edge of the curb or step. Then allow the large Drive wheels to slowly roll down onto the lower level.
 5. When the large Drive wheels are safely on the lower level, tilt the chair back to its balance point. This will lift the front casters off of the curb or step.
 6. Keep the chair in balance and take small steps backward. Turn the chair around and gently lower front casters to the ground.

Climbing a Curb or Single Step with Attendant

Follow these steps to help the rider climb a curb or single step going FORWARD

- 
- 
- 
- 
- 
- 
- 
- 
- W**
A
R
N
I
N
G
1. Stay behind the chair.
 2. Face the curb and tilt the chair up on the large Drive wheels so that the front casters clear the curb or step.
 3. Move forward, placing the front caster on the upper level as soon as you are sure they are past the edge.
 4. Continue forward until large wheels contact the face of the curb or step. Lift and roll the large wheels to the upper level.

Climbing Stairs

1. Use at least two attendants to move a chair and rider up stairs.
2. Move the chair and rider BACKWARD up the stairs.
3. The person at the rear is in control. He or she tilts the chair back to its balance point.
4. A second attendant at the front firmly grasps a non-detachable part of the front frame and lifts the chair up and over one stair at a time.
5. The attendants move to the next stair up. Repeat for each stair until you reach the landing.

Descending Stairs

1. Use at least two attendants to move a chair and rider down stairs.
2. Move the chair and rider FORWARD down the stairs.
3. The person at the rear is in control. He or she tilts the chair to the balance point of the rear wheels and rolls it to the edge of the top step.
4. A second attendant stands on the third step from the top and grasps the chair frame. He or she lowers the chair one step at a time by letting the rear wheels roll over the stair edge.
5. The attendants move to the next stair down. Repeat for each stair, until you reach the landing.



Tilting Seat

1. Set wheel lock prior to seat tilt adjustment.
2. Make sure that the floor surface is level when adjusting tilt.
3. Keep both hands on handgrips while using your right foot to tilt seat forward or back.

If you fail to heed these warnings, damage to your chair, a fall, tip-over, or loss of control may occur and cause severe injury to the rider or others.



Maintenance

1. Inspect and maintain this chair strictly per instructions on page 34.
2. If you detect a problem, make sure to service or repair the chair before use.
3. At least once a year, have a complete inspection, safety check and service of your chair made by an authorized Freedom Designs, Inc. provider.

WARNING: COMPONENTS & OPTIONS

Transport Option

1. Use only Wheelchair Tiedown and Occupant Restraint Systems, (WTORS) which meet the requirements of SAE J2249 Recommended Practice— Wheelchair Tiedown and Occupant Restraint Systems Use In Motor Vehicles. **Do not** use WTORS designed to rely on the wheelchair structure to transfer occupant restraint loads to the vehicle. Note: **Use only a four-point wheelchair tiedown with an integrated three-point occupant restraint system.**
2. The wheelchair has been dynamically tested in a forward-facing mode for a 48-km/h frontal impact. The wheelchair must be forward-facing during transport.
3. In order to reduce the potential of injury to vehicle occupants, wheelchair mounted accessories, such as trays and respiratory equipment, should be removed and secured separately.
4. Postural supports and positioning devices should not be relied on for occupant restraints.
5. Do not alter or substitute wheelchair frame parts, components or seating.
6. Sudden stops or impacts can structurally damage your chair. Chairs involved in such incidents should be replaced.

Anti-Tip Device

Anti-tip tubes help keep your chair from tipping over backward in most normal conditions. Freedom Designs, Inc. recommends that the anti-tip tubes be used at all times and may not be removed from the wheelchair.

1. If modifications or adjustments are done to the wheelchair, anti-tip tubes must be used to prevent tipping backward.
When locked in place, (the “down” position), anti-tip tubes should be BETWEEN 1 1/2” to 2” off the ground.
 - a. If set too HIGH, they may not prevent a tip-over.
 - b. If set too LOW, they may “hang up” on obstacles you can expect in normal use. If this occurs, you may fall or your chair may tip over.

Caution must always be used when tipping the wheelchair backward.

Armrests

Armrests may detach or flip up and will not bear weight of this chair.

1. **NEVER** lift this chair by the armrests. They may come loose or break.
2. Lift this chair only by non-detachable parts of the frame.

Cushions and Sling Seats

1. Freedom Designs, Inc. sling seats and standard foam cushions are not designed for the relief of pressure.

If you fail to heed these warnings, damage to your chair, a fall, tip-over, or loss of control may occur and cause severe injury to the rider or others.



W

A

R

N

I

N

G





Warning: For Safe Use



2. If you suffer from pressure sores, or if you are at risk that they will occur, you may need a special seating system or a device to control your posture. Consult your doctor, nurse, or therapist to find out if you need such a device for your well-being.

Fasteners

Many of the screws, bolts and nuts on this chair are special high-strength fasteners. Use of improper fasteners may cause your chair to fail.

1. **ONLY** use fasteners provided by an authorized Freedom Designs, Inc. provider.
2. Over or under tightened fasteners may fail or cause damage to chair parts.
3. If bolts or screws become loose, tighten them as soon as possible.

Footrests

1. At the lowest point, the footrest should be **AT LEAST 2 1/2"** off the ground. If set too **LOW**, it may "hang up" on obstacles you can expect to find in normal use. This may cause the chair to stop suddenly and tip forward.

2. To avoid a trip or fall when you transfer:
 - a. Avoid putting excessive weight on the footrest, as the chair may tip forward.
3. **NEVER** lift this chair by the footrest. Footrests are not designed to bear the weight of this chair.

Pneumatic Tires

Proper inflation extends the life of your tires and makes your chair easier to use.

1. Do not use this chair if any of the tires is under or over inflated. Check weekly for proper inflation level, as listed on the tire sidewall.
2. Low pressure in a large tire may cause the wheel lock on that side to slip **AND** allow the wheel to turn when you do not expect it.
3. Low pressure in any tires may cause the chair to veer to one side and result in a loss of control.
4. Over inflated tires may burst.

Positioning Belts

Use positioning belts **ONLY** to help support the rider's posture. Improper use of these belts may cause severe injury to or death of the rider.

1. Make sure the rider does not slide down in the wheelchair seat. If this occurs, the rider may suffer chest compression or suffocate due to pressure from the belts.
2. The belts must be snug, but must not be so tight that they interfere with breathing. You should be able to slide your 2 fingers between the belt and the rider.
3. Use positioning belts only with a rider who can cooperate. Make sure the belt can easily be removed in an emergency.
4. **NEVER** use positioning belts:
 - a. As a patient restraint. A restraint requires a doctor's order.
 - b. On a rider who is comatose or agitated.
 - c. As a motor vehicle restraint. In an accident or sudden stop, the rider may be thrown from the chair. Wheelchair positioning belts will not prevent this and further injury may result from the belts or straps.

If you fail to heed these warnings, damage to your chair, a fall, tip-over, or loss of control may occur and cause severe injury to the rider or others.

W
A
R
N
I
N
G





Power Drive

Freedom Designs, Inc. does not recommend the attachment of power drives to the NXT wheelchair.

1. The attachment of power drives to the wheelchair is considered a modification or alteration to the frame, thus voiding the warranty.
2. Balance and stability may be affected, thereby causing unsafe conditions.



Push Handles

When you have an attendant, make sure that this chair has push handles.

1. Push handles provide secure points for an attendant to hold the rear of this chair, to prevent a fall or tip-over. Make sure to use push handles when you have an attendant.
2. Check to make sure push handles grips will not rotate or slip off.
3. **DO NOT** lift chair with stroller handles or stroller handle extensions.

W

A

R

N

I

N

G

Quick Release Axles

1. Do not use this chair **UNLESS** you are sure that both quick release axles are locked. An unlocked axle may come off during use and cause a fall.
2. An axle is not locked until the quick release button pops out fully. An unlocked axle may come off during use, resulting in a fall, tip-over or loss of control and cause injury to the rider or others.

Large Drive Wheels

A change in setup of the large Drive wheels will affect the center of balance of your chair.

1. The farther you move the large Drive wheel axles **FORWARD**, the more likely it is that your chair will tip over backward.
2. Consult your doctor, nurse, or therapist to find the best Drive wheel axle setup for your chair.
3. Adjust the wheel locks after you make any change to the Drive wheel axles.
 - a. If you fail to do so, the locks may not work.
 - b. Make sure lock arms embed in tires at least 1/4" when locked.

Wheel Locks

Wheel locks are **NOT** designed to slow or stop a moving wheelchair. Use the wheel locks only to keep the Drive wheels from rolling when your chair is at a complete stop.

1. **NEVER** use wheel locks to try to slow or stop your chair when it is moving. Doing so may cause you to veer out of control.
2. To keep the drive wheels from rolling, always set both wheel locks when you transfer to or from your chair.
3. Low pressure in a large Drive wheel tire may cause the wheel lock on that side to slip and may allow the wheel to turn when you do not expect it.
4. Make sure lock arms embed in tires at least 1/4" when locked. If you fail to do so, the locks may not work.



Modified Seating System

Use of a seating system not approved by Freedom Designs, Inc., may alter the center of balance of this chair. This may cause the chair to tip over.

If you fail to heed these warnings, damage to your chair, a fall, tip-over, or loss of control may occur and cause severe injury to the rider or others.



**Warning:
For Safe Use**



1. Do not change the seating system of your chair UNLESS you consult your authorized Freedom Designs, Inc. provider first.
2. Use of a seating system not approved by Freedom Designs, Inc. may affect the folding mechanism of this chair.
3. Use of a seating system not approved by Freedom Designs, Inc. is prohibited for transportation use with Freedom Designs, Inc. Transport Option.



Upholstery Fabric

1. Sling fabric will weaken with age and use. Look for fraying or thin spots, stretching of fabrics at rivet holes.
2. “Drooping Down” into your chair will weaken fabric and result in the need to inspect and replace the seat more often.
3. Be aware that laundering or excess moisture will reduce flame retardation of the fabric.

W

A

R

N

I

N

G



If you fail to heed these warnings, damage to your chair, a fall, tip-over, or loss of control may occur and cause severe injury to the rider or others.



The NXT is shipped in the following fashion:

1. The main frame with backposts, casters, tires, with quick release axles, armrests*, footplates or footboard and anti-tip tubes. (Refer to the Unfold instructions in this manual).
2. Optional armrests would be attached to the backposts or solid seat insert.

*Armrest might be optional, dependent upon frame.

When Unpacking:

1. Check for any obvious damage to the box or its contents.
2. Remove all the loose packing from the box.
3. Carefully remove all of the components.
4. Examine the exterior of the NXT and the components for any nicks, dents, scratches or other damage.

NXT

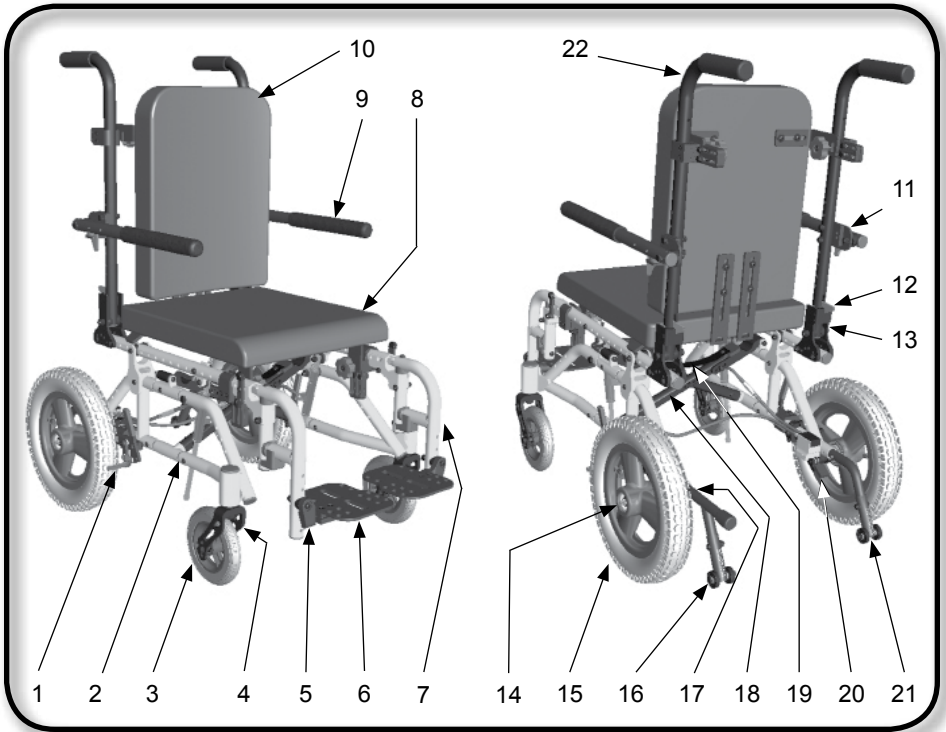

1. Wheel Lock
2. Base Frame
3. Caster Wheel
4. Caster Fork
5. Height Adjustable Hanger Clamp
6. Flip-up Footplates
7. Swing Away Hanger (pop-up or latch style)
8. Solid Seat (optional)
9. Flip up Arm
10. Solid Back (optional)
11. Arm Height Adjustment Clamp

12. Backpost Release Trigger
13. Backpost Adjustment Plate
14. Quick Release Axle
15. 12" Mag Wheel
16. Anti-tip Tube with Leverage Bar
17. Axle Adjustment Plate
18. Folding Crossbraces
19. Lifting / Folding Strap
20. Tilt Release Foot Pedal
21. Anti-tip Tube without Leverage Bar
22. Backpost



Seat Frame Receiver

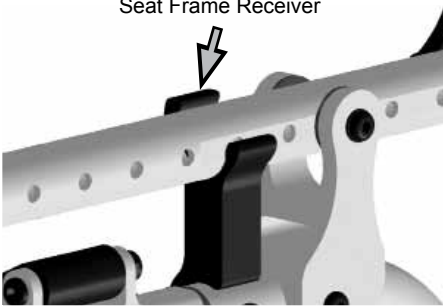

For ease of transporting and lifting, the NXT can be easily unfolded and folded.

Always engage the wheel locks by pushing forward or pulling back on the levers or engaging the foot lock before unfolding the chair. (see page 26).

1. Unfolding is accomplished by applying even downward pressure on the cross braces. The cross braces will lock into place.

Note: The cross braces need to be opened to their maximum point where the stops rest in the notches of the cross brace and lock into place.

2. Grasp the push handles and push them to an upright position where they will lock into place in the seat frame receivers. *This operation must always be done prior to assembling the seating to the wheelchair.*

3. Push the flip back armrests down to the flat position or insert optional T-arm or Dual Post Armrests into receiver socket until it snaps into place.



4. Attach Footrest Hangers
(See pages 21-22)

Note: *The NXT can be folded and unfolded while the footrest hangers are attached.*



5. Flip down the footplates or attach the footboard and place in the “down” position.
(See pages 23-24)

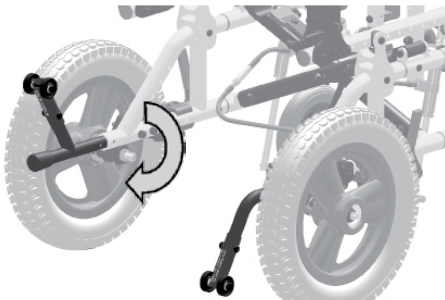

6. Turn both anti-tip tubes to the downward position until they “click” into place.
(See page 20).



Always engage the wheel locks by pushing forward or pulling back on the levers or engaging the foot lock before unfolding the NXT. (see page 26).

1. Flip up the individual footplates or remove the footboard. (See pages 23-24).

Note: *The NXT can be folded and unfolded while the footrest hangers are attached.*



2. Remove the footrest hangers. (See pages 21-22)



3. Flip back the armrests to the upright position.

Or remove armrests

Note: *The armrests need not be removed to fold the NXT but must be removed to fold the backposts down.*

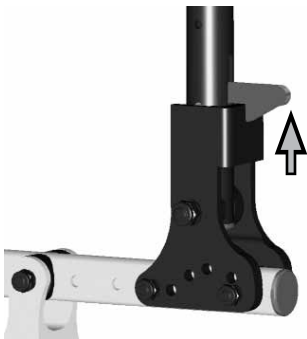

4. Pull up on the trigger mechanism for the backposts and push the backposts to the flat position over the seat rails.

Folding the NXT

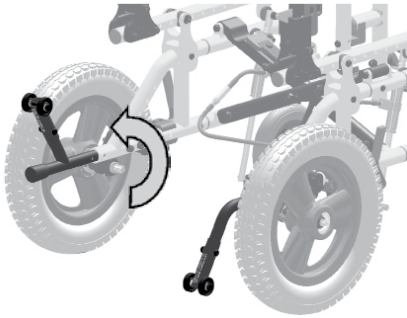

5. Rotate the anti-tip tubes upward as shown until they “click” into place.

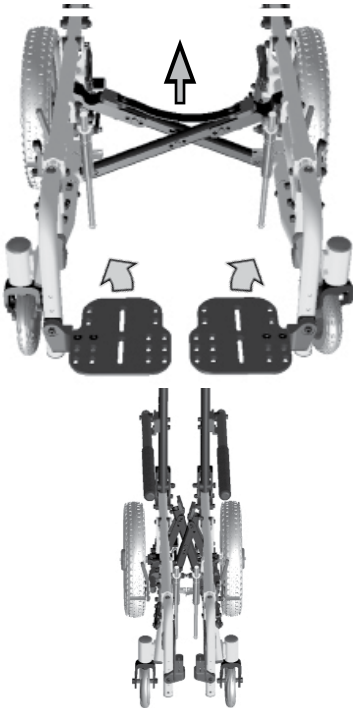

6. Pull up on nylon cross brace strap to fold the chair.

Note:

Use the provided nylon strap to fold the chair.

Be careful not to place your fingers between the folding crossbrace.

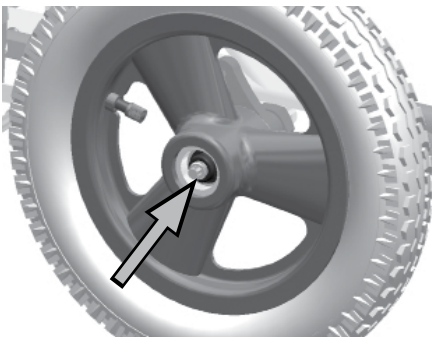

7. Disengage wheel lock, push the quick release axle button and pull wheel off of the frame.

Latch Style Swing Away Hangers

The NXT frames ship standard with swing-away hangers in 75° or 90°



1. To swing away the hanger, place your finger tip on the inside of the hanger release lever.



2. Pull outward on the lever (away from the chair). This will enable the hanger to swing away for ease of transfer.



3. To remove the hanger, lift the hanger upward until the pivot saddle is out of its frame receiver.



4. To attach the hanger, insert the pivot bushing into the frame receiver tube, at an angle as shown. Rotate the hanger inward until the latch snaps into place.

Pop-Up Removable Hangers

The NXT frames may be shipped with optional pop-up hangers in 75° or 90°.

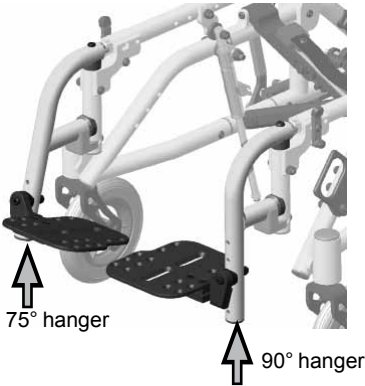

1. To remove the hanger, place your hand on the hanger release lever.



2. Pull back on the lever towards the chair. This will enable the hanger to pop-up and swing away for ease of transfer.



3. To remove the hanger, lift the hanger upward until the pivot saddle is out of its receiver on the frame.

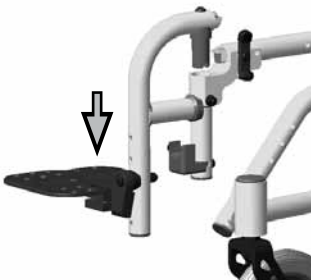

4. To attach the hanger, line up the pivot saddle with its receiver on the frame and insert downward pressure until the hanger locks into place.

Flip-up Individual Footplates

The NXT is shipped with individual flip-up footplates attached or a solid footboard unattached. Adjustment of the individual flip-up footplates are as follows:

To adjust the height of the footplate :

1. Remove the nylon lock nut on the back side of the hanger. Place the footplate at the desired height. Insert the screws through holes in the hanger tube, install lock nut and tighten securely.

To adjust the angle of the flip-up footplate

2. Loosen the screws on bottom of the footplate. Set the footplate at the desired angle and re-tighten.

To adjust the depth of the flip-up footplate

3. Loosen and remove the screws on top of the footplate. Align the holes in the footplate with holes in the clamp at the desired depth install the screws and tighten.

To flip the footplate

4. The individual footplates easily flip by lifting underneath the footplate to flip up or push down on the footplate to flip down.

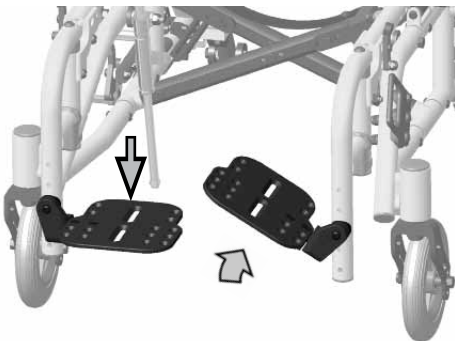
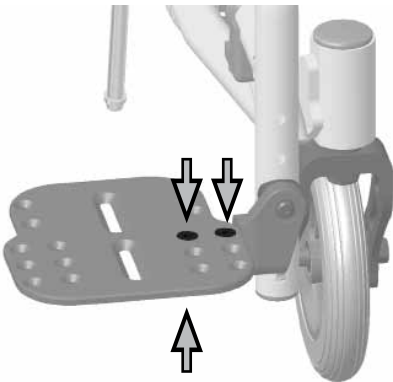
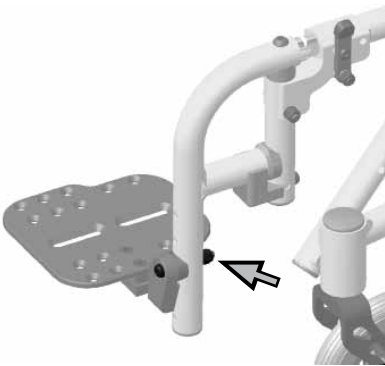

Angle Adjustable Footboard

1. To attach the footboard to the frame, place the footboard clamps on the frame. Set the clamps at the desired height. Insert the receiver into the clamps and tighten the 2 hex head screws on each side.
2. To remove the footboard for transfer, screw the knob assemblies underneath the receivers. Lift the footboard upward, out of the receivers.
3. To attach the footboard after transfer, align the footboard fittings into the receivers. Turn the knobs on each side to tighten.
4. To change the angle of the footboard, use an allen wrench and loosen the flat head screws on the top of the footboard. When the desired angle or depth is reached, tighten both screws.
5. To change the height of the footboard on the frame, loosen the 2 hex head screws on the footboard frame clamps. Set the desired height and tighten.

The lowest point of the footrest plate should be at least 2 1/2" from the ground to ensure the proper clearance.

Warning:

In all footplate and hanger adjustments, be sure that all screws are tightened securely for your safety.

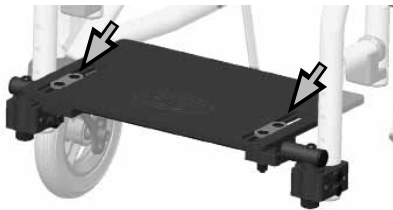
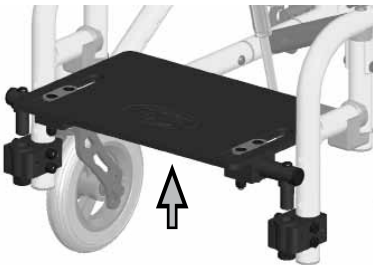
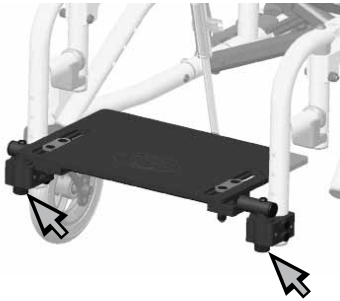



Quick Release Axle*

The NXT is equipped with double lock quick release axles that release with the push of a button. This double lock quick release mechanism allows the rear wheels to be easily removed for transportation or storage.

To remove the rear wheel:

1. Unlock the wheel lock.
2. Grasp the frame with one hand.
3. With the other hand, squeeze the quick release button.
4. The wheel will then pull off easily.

Warning:

The axle is not properly locked until the outside quick release button pops out to its full extended position.

**Patented*



Flip Back Arm

The NXT is shipped with flip back armrest as standard equipment. The flip back armrests are non removable and are available in either locking or non locking.

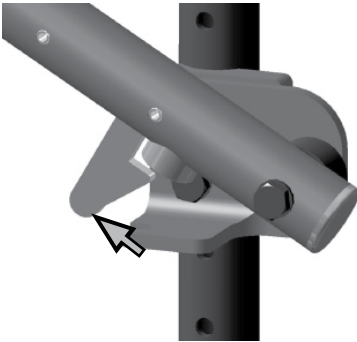

Locking Flip Back Arm

To flip the arm back, push the trigger mechanism

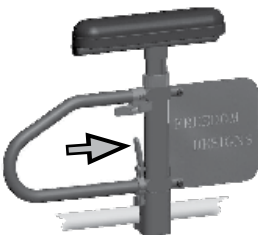

Single Post Height Adjustable "T" Arm

To remove the "T" arm, push lever toward the center post and lift arm out of receiver socket.

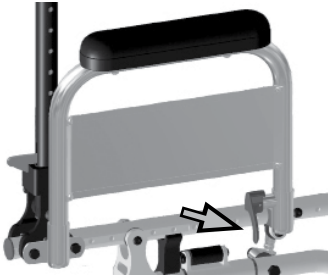

Dual Post Fixed Height Armrest

1. To remove the armrest, lift the release lever at the front of the seat frame and lift the arm out of the arm receiver tubes.
2. To replace the arm, insert the arm into the receiver tubes and rotate the release lever to the downward position.

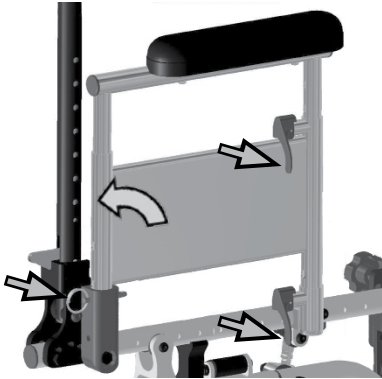

Dual Post Flip Back Adjustable Height Armrest

1. To flip the arm back, rotate the release lever at the front of the seat frame, upward to the horizontal position. The arm is now free to rotate backward.
2. To adjust the arm height, flip the release lever (under the front of the arm pad) to the horizontal position. Slide the arm upward to the desired location. Flip the release lever back to the vertical position.
3. To remove the arm, flip the front release lever to the horizontal position and pull the pin from the rear receiver tube.



Casters

The NXT comes shipped with either 3" polyurethane casters with a 3" caster fork or 5", 6", 7" pneumatic casters with 6" caster fork.

Push or Pull to Lock Wheel Locks

The NXT comes standard with push to lock or pull to lock wheel locks.

To lock wheels in place:

1. Grasp the lever of the wheel lock with your hand.
2. Pull or push the lever back or forward to release the wheel lock.

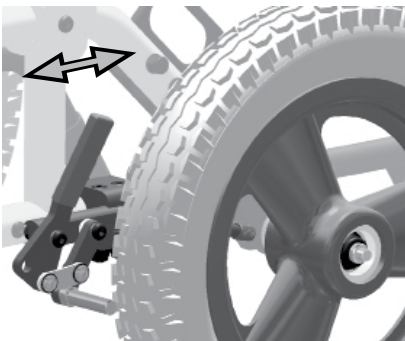

CAUTION



Always set the wheel locks when entering or leaving the wheelchair. Wheel locks are not designed to slow the wheelchair down when it is moving. Wheel locks hold the wheelchair in place when it is at a complete stop.

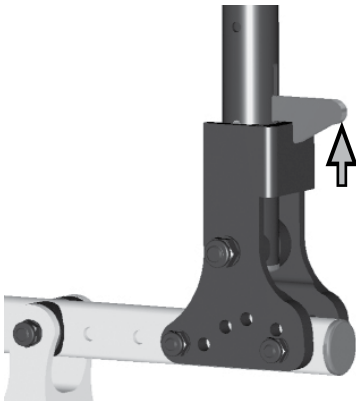

Folding Back

The NXT come standard with a folding back.

1. To fold the back down, pull upward on the trigger while pushing backposts forward toward seat.
2. To place the backpost to the upright position, pull backposts up until trigger snaps into place.

Note:

The backposts fold down completely when using a solid seat and back. When using a sling seat and back the backposts will only fold partially

Tilt Operation

The standard method of tilt activation is with the use of a foot pedal. A single back cane mounted release is optional.

Foot Pedal Release Procedure

Rearward Tilt

1. Engage wheel locks.
2. To activate the tilt on the NXT, grip the push handles with both hands, press down on the foot pedal and hold down (flip foot pedal down if necessary) and rotate the push handles downward.
3. When the angle of tilt is in the desired position, release the foot pressure. The tilt will lock into place.

Forward Tilt (toward flat seating position)

1. Engage wheel locks.
2. To bring the NXT seat and back frame toward the upright position (out of tilt), grip the push handles with both hands, press down on the foot pedal and hold down, rotate the push handles upward.
3. Release the foot pressure when the forward tilt position has been achieved.

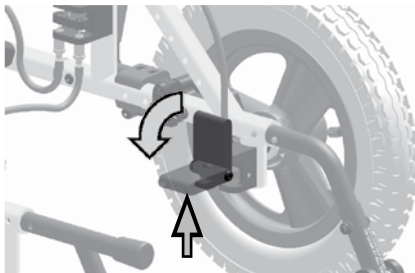

Foot Pedal

Rotate Back Canes



Foot Pedal

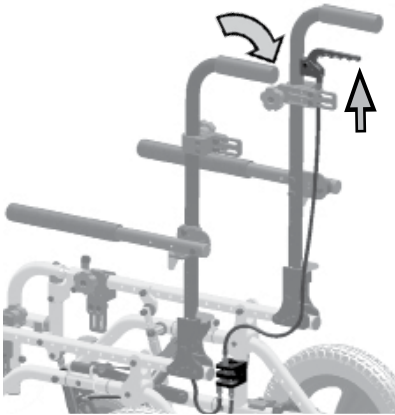

Back Cane Lever Release Procedure

Rearward Tilt

1. Engage wheel locks.
2. To activate the tilt on the NXT using the optional back cane mounted lever, grip the push handles with both hands while also gripping the release lever. Squeeze the lever and hold while rotating the push handles downward.
3. When the angle of tilt is in the desired position, release the lever. The tilt will lock into place.

Forward Tilt (toward flat seating position)

1. Engage wheel locks.
2. To bring the NXT seat and back frame toward the upright position (out of tilt), grip the push handles with both hands, while gripping the release lever. Squeeze the lever and hold down while rotating the back canes upward.
3. Release the pressure on the lever when the forward tilt position has been achieved.

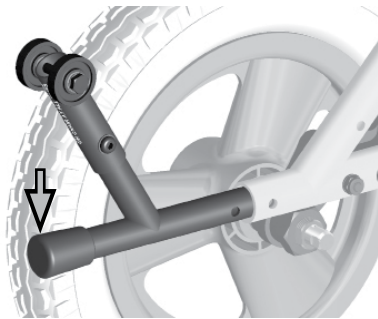

Leverage Bar Instructions

One of the anti-tip assemblies may be used as a leverage bar to assist in tipping the wheelchair in order to roll over curbs and other obstacles.

Rotate the anti-tip assemblies to the upward position (see picture) Place your foot on the straight portion of the tipping lever. Press down with your foot while pulling back and pushing downward on the backrest push handles.

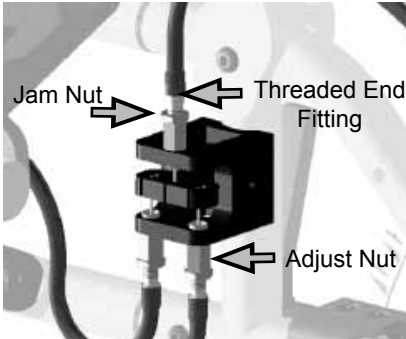

Tilt Cable Adjustment

At least one end of each cable will have a threaded end fitting, adjust nut & jam nut. If the seat tilt locks do not release when the foot pedal or hand lever is depressed, loosen the jam nut and adjust the threaded end fitting outward (turn adjust nut counterclockwise). If the lock does not hold properly adjust the threaded end fitting inward (turn large nut clockwise). Re-tighten the jam nut securely.

Note:

Seat lock cables should be adjusted by a qualified technician.

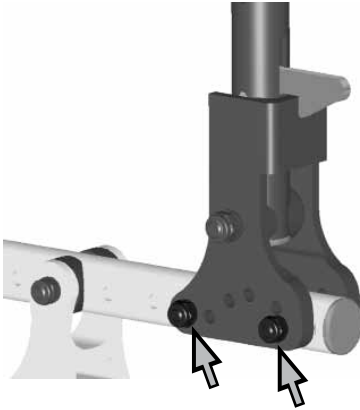

Backpost Adjustment

The angle and depth of the backposts may be adjusted by repositioning the backpost pivot plate in the pre-drilled holes on the frame.

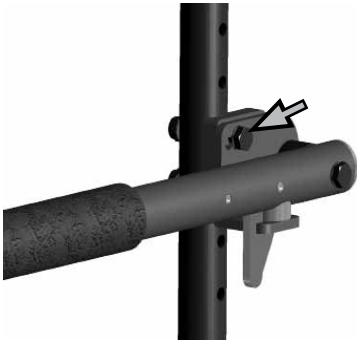

Flip Arm / Locking Arm

To adjust height of armrests, loosen and remove the bolts and nuts holding the arm to the backpost tube. Align holes in arm with holes in backpost tube at desired height. Re-assemble with bolts and nuts.



“T” Arm

To adjust the height of the “T” arm, rotate lever outward. Lift or lower arm pad to desired height and rotate lever back to forward position to lock in place.

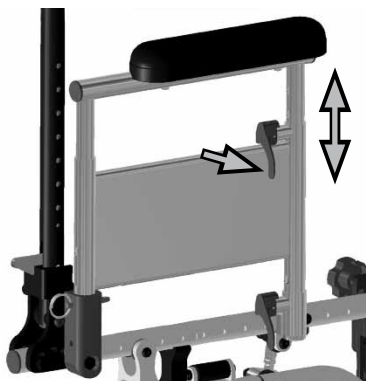

Adjustable Height Flip Back Armrest

To adjust the arm height, flip the release lever (under the front of the arm pad) to the horizontal position. Slide the arm upward to the desired location. Flip the release lever back to the vertical position.



Caster Fork Adjustment

Interchanging casters can easily be done with dual hole caster forks. Currently, 3", 5", 6" and 7" casters are available for use. A smaller fork is used with the 3" caster only. To adjust, loosen the bolt and remove the caster. Change the caster and/or position the caster upward or downward in pre-drilled holes on the caster fork. Replace the bolt and tighten securely.

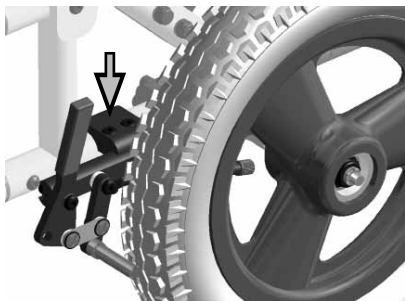

Wheel Lock Adjustment

When the rear wheel is repositioned, it is important that the wheel lock is readjusted also.

Adjustment can be made by loosening the 1/4-20 x 1" button head screws and sliding the wheel lock assembly along the frame tubing so that the wheel lock contacts the tire in the locked position. Continue to adjust until the knurled grip handle embeds into the tire approximately 1/4" when in the locked position. Tighten the screw until wheel lock is snug to frame tube.



WARNING



Wheel locks are not designed to slow the chair down when it is moving. When the chair is stopped, engaging properly adjusted wheel locks will prevent the rear wheels from turning.

Rear Axle Adjustment

The position of the rear axle is the most critical adjustment on the NXT wheelchair. The center of gravity and the seat height position are all determined by the axle adjustment.

Warning:

Your healthcare professional should assist you in adjusting the axle position. Position of the axle will be based on your abilities and limitations.

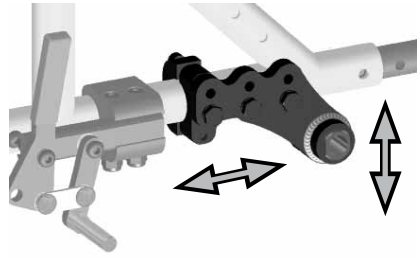

Center of gravity adjustment may be accomplished by moving the rear axle plate forward or backward on the frame.

Seat height and/or angle may be changed by changing the position of the axle upward or downward on the axle plate.

Warning:

Your healthcare professional should assist you in adjusting the axle position. Position of the axle will be based on your abilities and limitations.

Warning:

The wheelchairs become less stable if forward axle positions are used. The further forward the axles are positioned, the easier it is to tip the chair over forward or backward. Moving the axle backward will increase the stability of the chair. This backward adjustment will create increased turning pressure.

Note:

A front caster adjustment should be made to correspond with any changes in rear seat height/angle.

Anti-tip Lever Adjustment

Height

1. Loosen the screw and nut on the anti-tip roller assembly.
2. Raise or lower anti-tip roller assembly until desired height is attained. (recommended at 1-1/2" to 2" off of the ground).
3. Re-install screw and nut. Tighten securely.
4. Repeat procedure on opposite anti-tip lever.



Pelvic Belt Installation

1. Remove the pelvic belt and component from packaging.
2. Inspect the belt and hardware to ensure that there are no missing or damaged parts.

3. (2-point belts)

Locate the rear most hole in the seat frame tube of the wheelchair. Slide a washer onto screw and insert through the grommet or triangular bracket (depending on belt type) and last hole in seat rail tube. Install washer and lock nut.

Repeat procedure on opposite side of the chair.

Tighten all hardware securely.



(4-point belts)

Locate the rear most hole in the seat frame tube of the wheelchair. Slide a washer onto screw and insert through the grommet or triangular bracket (depending on belt type) of the rear belt (thicker strap) and last hole in seat rail tube. Install washer and lock nut. Next locate a hole in the seat frame 2"-3" forward of the other strap. Repeat assembly procedure for forward strap.

Repeat assembly procedure for opposite side of the chair.

Tighten all hardware securely.

Pelvic Belt Adjustment

Ensure that the user is sitting correctly, with their bottom as far back in the seat as possible. Position the lap belt around the user in the desired position and push the two sides of the buckle together.

Adjust the length of the lap strap using the pulls on the side(s) of the clasp. The belt should be a snug fit without causing discomfort. There should be sufficient room to slide two fingers between the user and the belt. For ease, the clasp should be kept in a central position.

To Release the Belt

See table below for release instructions.

Pelvic Belt Style	Release Instructions
Squeeze	Using the thumb and forefinger, squeeze the two plastic buttons at the top and bottom of the buckle
Push Button (Plastic and Metal)	Push the button in the center of the buckle.
Airline	Lift the metal flap on the buckle

Cleaning

It is important for optimum performance to clean and maintain your NXT. We recommend that the frame finish be cleaned with mild soap and water.

Maintenance

1. In order to operate the NXT properly and safely, routine maintenance will extend the life and efficiency of your wheelchair.

Safety Inspection Checklist

Follow these maintenance procedures for optimum performance of your NXT wheelchair:

1. Check to see that the wheelchair rolls straight.
2. Tires: Check for flat spots, wear and proper inflation.
3. Wheel lock:
 - a. Check to see that the locks engage easily.
 - b. Check that the locks are free of wear
 - c. Check to see that the locks do not interfere with the tires when rolling.
4. Ensure that all fasteners are secure.
5. Casters: Inspect axle for proper tension. Spin the caster. The caster should spin freely and come to a gradual stop.

Storage

The NXT folds down to a small unit and the rear wheels may be removed. We suggest when storing the wheelchair, that it be stored in an indoor, cool and dry area.

Troubleshooting

All NXT wheelchairs leave the factory inspected and adjusted for immediate use, (aside from the unfolding procedure). This troubleshooting chart offers some suggestions regarding the use of your wheelchair. Some areas may require more investigation to find the most suitable solution for a specific problem. A complete inspection, safety check, and servicing should be made by an authorized provider at least once a year. Any problems should be directed to your authorized provider or call our customer service department.

Symptoms	Remedy
The wheelchair veers right:	<p>Check that both casters contact the ground at the same time.</p> <p>Check that the tire pressure is correct and equal in both rear wheels.</p>
The wheelchair veers left:	<p>Check that both casters contact the ground at the same time.</p> <p>Check that the tire pressure is correct and equal in both rear wheels</p>
Sluggish turning or performance:	<p>Check that all nuts and bolts are tight.</p> <p>Check that the tire pressure is correct and equal in rear wheels.</p>
Caster flutter:	<p>Check that all nuts and bolts are tight.</p> <p>Check that both casters contact the ground at the same time.</p> <p>Check for wear of casters.</p>
Squeaks and rattles:	<p>Check that all nuts and bolts are tight.</p>
Looseness in the wheelchair:	<p>Check that all nuts and bolts are tight.</p>

Congratulations on your NXT purchase. Following is a brief summary to refer to if you have any questions. Remember: the entire Operating Manual should be read before your new chair is used. For any questions, please call your authorized Freedom Designs, Inc. provider or Freedom Designs, Inc. customer service at:

1-800-331-8551

Note: Always lock the wheel locks before adjusting the wheelchair.

Unfolding the NXT:

1. Place tires on quick release axles and push in until quick release push button “pops out” and wheels are secure.
2. Apply even pressure on the seat rails and push down.
3. Fold down arms or install armrests.
4. Attach hangers
5. Push footplates down or attach the footboard.
6. Adjust anti-tip tubes to the downward or rearward position.

Folding the NXT:

1. Flip up the individual footplates or remove the solid footboard.
2. Remove footrest hangers.
3. Fold up or remove armrests.
4. Pull up on nylon crossbrace strap to fold chair.
5. Squeeze quick release axle button and pull wheel off of the frame.

Quick Release Axle:

1. Unlock the wheel locks.
2. Grasp the frame with one hand.
3. With your other hand, squeeze the quick release button.
4. The wheel will then pull off easily.

Push to Lock Wheel Lock: To Lock

1. Grasp the lever of the wheel lock with your hand.
2. Push the lever forward to a locked position.

To Unlock

1. Grasp the lever of the wheel lock with your hand.
2. Pull the lever back to release the wheel lock.

Freedom Designs, Inc. Limited Warranty

PLEASE NOTE: THE WARRANTY BELOW HAS BEEN DRAFTED TO COMPLY WITH U.S. FEDERAL LAW APPLICABLE TO PRODUCTS MANUFACTURED AFTER JULY 4, 1975. THIS WARRANTY IS EXTENDED ONLY TO THE ORIGINAL PURCHASER/USER WHO PURCHASES THIS PRODUCT WHEN NEW AND UNUSED DIRECTLY FROM FREEDOM DESIGNS OR AN AUTHORIZED DEALER OR DISTRIBUTOR. THIS WARRANTY GIVES SPECIFIC LEGAL RIGHTS AND YOU MAY ALSO HAVE OTHER LEGAL RIGHTS WHICH VARY FROM STATE TO STATE, OR COUNTRY TO COUNTRY.

Limited Warranty – USA: All Freedom Designs' wheelchair frames, quick release axles and hardware are warranted against defects in material and workmanship for five (5) years from the date of purchase. All other manufactured and distributed parts and components (including frame components, axle plates, armrests and backrests) are warranted for one (1) year from said purchase date. There is no warranty for tires, tubes, and push handle grips. If within such warranty periods any product component eligible for coverage under this warranty shall be proven to be defective, Freedom Designs will, at its option, either replace or repair the product with new or refurbished product components, or will supply the original purchaser with replacement product components, which may be either new or refurbished. Freedom Designs' sole obligation and your exclusive remedy under this warranty shall be limited to such repair and/or replacement. This warranty does not include any labor or shipping charges incurred in replacement part installation or repair. Moreover, the warranty period of the repaired or replaced product component shall terminate with the termination of the warranty period for the original product component. Freedom Designs' sole obligation and your exclusive remedy under this warranty shall be limited to such repair and/or replacement.

Limited Warranty - International: All Freedom Designs' wheelchair frames & quick release axles are warranted against defects in material and workmanship for five (5) years from the date of purchase. All other manufactured and distributed parts and components (including frame components, axle plates, armrests and backrests) are warranted for one (1) year from said purchase date. All hardware is warranted for two (2) years after the date of purchase. There is no warranty for tires, tubes, and push handle grips. If within such warranty periods any product component eligible for coverage under this warranty shall be proven to be defective, Freedom Designs will, at its option, either repair or replace the product with new or refurbished product components, or will supply the original purchaser with replacement product components, which may be either new or refurbished. Freedom Designs' sole obligation and your exclusive remedy under this warranty shall be limited to such repair and/or replacement. This warranty does not include any labor or shipping charges incurred in replacement part installation or repair. Moreover, the warranty period of the repaired or replaced product component shall terminate with the termination of the warranty period for the original product component. Freedom Designs' sole obligation and your exclusive remedy under this warranty shall be limited to such repair and/or replacement.

Limitations & Exclusions – USA & International: The foregoing limited warranties shall not apply to: Tires, tubes and push handle grips; Serial numbered products if the serial number has been removed or defaced; Products subjected to negligence, accident, improper operation, maintenance, or storage; Products modified without Freedom Designs' express written consent including, but not limited to, modification through the use of unauthorized parts or attachments; Products damaged by reason of repairs made to any component without the specific consent of Freedom Designs, or to products damaged by circumstances beyond Freedom Designs' control; Problems arising from normal wear or failure to adhere to these instructions; and with any such warranty eligibility evaluation to be solely determined by Freedom Designs,.

THE FOREGOING LIMITED WARRANTIES ARE EXCLUSIVE AND IN LIEU OF ANY OTHER WARRANTIES WHATSOEVER, WHETHER EXPRESS OR IMPLIED, INCLUDING THE IMPLIED WARRANTIES OF MERCHANTABILITY AND FITNESS FOR A PARTICULAR PURPOSE, AND THE SOLE REMEDY FOR VIOLATIONS OF ANY WARRANTY WHATSOEVER SHALL BE LIMITED TO REPAIR OR REPLACEMENT OF THE DEFECTIVE PRODUCT PURSUANT TO THE TERMS CONTAINED HEREIN. THE APPLICATION OF ANY IMPLIED WARRANTY WHATSOEVER SHALL NOT EXTEND BEYOND THE DURATION OF THE EXPRESS WARRANTY PROVIDED HEREIN. FREEDOM DESIGNS SHALL NOT BE LIABLE FOR ANY CONSEQUENTIAL OR INCIDENTAL DAMAGES WHATSOEVER. THESE WARRANTIES SHALL BE EXTENDED TO COMPLY WITH STATE PROVINCIAL LAWS AND REQUIREMENTS.

Returns: An authorization for return must be acquired by an established Freedom Designs, Inc. dealer/distributor before Freedom Designs will accept returned items. The dealer must return items to Freedom Designs, 2241 N. Madera Rd, Simi Valley, CA 93065 USA with freight pre-paid and fully insured with the R.A. # issued by customer service marked on the outside of the box. All returns must be received within 45 days of issuance of the R.A. #. Returns are subject to examination at the discretion of Freedom Designs and may be subject to a 25% restocking fee. Custom fabricated products are non-returnable.



Our kids are our passion.™

CE